

# **A methodology for identifying and formalizing farmers' representations of watershed management: a case study from northern Thailand**

N. Becu, O. Barreteau, P. Perez, J. Saising, and S. Sungted

Linking modeling tools and the participatory approach for development is not a common combination. Participatory multi-agent system modeling (PMASM) is a tool for sharing viewpoints among stakeholders and facilitating the negotiation process. A key question of this approach is the acquisition and the modeling of the various stakeholders' representations. Our research team, whose Asian branch is represented in this book, tries to formalize the passage from fieldwork to the model by defining a methodology that can be implemented in the field. This methodology adapts knowledge engineering acquisition techniques to in-field stakeholders' representations for PMASM. In a northern Thailand watershed, we pursued implementation tests of this methodology. We first explored two ways to tackle fieldwork (ethnographic and project surveys), both showing weaknesses and strengths. We then built a first-version diagram syntax used for representing individual farmers' representations, and we considered options for analyzing those diagrams. Finally, we tested the elicited representations by leading farmers, through game-like sessions, to rebuild a model of their system structured by elements and links. Results reveal a great heterogeneity of farmers' representations, which we intend to manage by establishing farmers' synthetic profiles based on their orientations toward specific elements and aspects of their social and natural environment. Orientations of those profiles convey different conceptions of the functioning of the system with which farmers interact. This also results in decisions and reactions to issues that are different from one profile to another. The identification and formalization will contribute to the implementation of a computer model of farmers' representations. Perspectives are drawn on two ways to integrate representations into the modeling.

During the last ten years, researchers have been working on natural resource management (NRM) and ecosystem modeling using multi-agent systems (MAS) (Carpenter et al 1999, Lansing 1991, Rouchier and Bousquet 1998). This research has focused mainly on the interactions between biophysical and social dynamics as a means to understand the emergent behaviors of a system. A subset of experimental studies resulted in the combination of MAS modeling and participatory approaches and demonstrated the ability of participatory MAS modeling (PMASM) to promote discussions among

stakeholders involved in the participatory process and lead them to defining negotiated scenarios (Bousquet et al 2002, Barreteau 2003, D'Aquino et al 2003, Etienne et al 2003). A key element of this approach is the construction of a shared representation of the system among participants. It consists of taking into account stakeholders' representations, emphasizing the differences among those representations, showing some participants the differences and similarities of the others' viewpoints, and facilitating a better understanding of the diverse views of the world. Thus, identifying and integrating stakeholders' representations is a necessary step of PMASM and the question emerging is how to formalize this step. This is the aim of this paper, which describes the setting up and application of methods for identifying and formalizing how farmers represent watershed management. This formalization will enable us to implement stakeholders' representations into a model in a next phase.

The field site of this research is a catchment located in northern Thailand. A great diversity of stakeholders intervenes in northern Thailand catchment management. There are cultural differences among stakeholders (northern Thai villages in the lowlands and various minority group settlers in the highlands), but also diversity in terms of stakeholders' involvement (farmers using resources, local extension and development offices, state intervention). Those various stakeholders are all involved at different levels in NRM and have recently been encouraged to interact more intensively together. Stakeholders' interactions in relation to NRM are not always smooth, and have sometimes led to tensions and conflicts. We tackle the analysis of those interactions from the angle of the representations that stakeholders have of catchment NRM. Indeed, in northern Thailand, we found that stakeholders have various views about the functioning of the social and natural system, about the issues to face, and the way to handle them. Identifying stakeholders' representations helps in understanding the functioning of stakeholders' interactions and the implications of their heterogeneous points of view.

In an early stage of our research, we laid out the elements of a methodology for identifying stakeholders' representations (Becu et al 2003). This methodology is based on the mutual use of knowledge engineering techniques (Gaines and Shaw 1993, Menzies 2002) and PMASM. The application of this methodology to the northern Thailand case study enabled us to identify and formalize a set of individual farmers' representations. Classifications of farmers' representations resulted in sets of farmers' profiles that demonstrate the heterogeneity of farmers' points of view. In this paper, we focus on the construction, application, and preliminary assessment of this methodology tested with local farmers. In the first part, we describe the field context and the modeling background. Then, we present our methodology, its application, and the results obtained. Finally, we assess the methods used and discuss the heterogeneity of the individual representations.

## Natural resource issues in northern Thailand

Three decades of agricultural transformation in northern Thailand have witnessed increasing tension in relation to NRM. Permanent settlement of upland community groups, farmers' adaptations to market demand, and the increasing degree of state intervention in the highlands have resulted in increasing interdependencies among

stakeholders. The 1997 National Constitution provides members of local communities the right to “*use and preserve their local natural resources and environment*” (section 46). It also requires the state to “*promote and encourage public participation in the preservation, maintenance, and balanced exploitation of natural resources [...] in accordance with sustainable development principles*” (section 79). These obligations are reinforced by the Eighth National Economic and Social Development Plan (1997-2001), which calls for a “*greater participation of local people and community organizations in the management of natural resources*” (Missingham 2000). Hence, various local stakeholders are now strongly encouraged to interact and collaborate on water management issues.

Meanwhile, tensions among stakeholders in relation to NRM are increasing and open conflicts are sometimes erupting (Vorapien 1994, Kanwanich 1997). In particular, several governmental and nongovernmental organizations in northern Thailand claimed that deforestation resulted in a dramatic decrease in water availability during the dry season. This assumption was repeatedly mentioned by lowland farmers to accuse upland settlers of reducing downstream flow. However, issues as fundamental as the relationship between upland agriculture and forest destruction or the impact of upstream agricultural intensification on downstream agricultural viability are contested by several experts (Alford 1992, Enters 1995, Schmidt-Vogt 1998). They argue that the expansion of irrigated schemes and horticulture in the lowlands are responsible for an increasing water demand. Supporters argue that these evolutions have increased the demand for water during the dry season, which now has to face a fluctuating water supply (Walker 2003, Waranoot and Bengtsson 1993). If deforestation and catchment hydrological equilibrium are often driving social tensions, related issues such as soil conservation, erosion, or irrigation infrastructure management are also sometimes leading to highly contentious management options.

Recent literature on environmental management, and catchment management in particular, places a strong emphasis on achieving negotiated settlements to such conflicts (Brown et al 1995, Crowfoot and Wondolleck 1990). In northern Thailand, such approaches are often seen as an appropriate way forward in a social and political climate that places increasing emphasis on participation. Understanding the interactions among stakeholders having different interests and viewpoints is one step in such an arrangement. In this perspective, multi-agent-based modeling used together with knowledge engineering techniques may help explain these interactions.

## Modeling representations with multi-agent systems

MAS focus on interactions between agents as a means to understand the emergent behavior of a system (Ferber 1995). That is how a multi-agent model can simulate the interactions between two agents gathering a resource, with each having a different view about that resource (Epstein and Axtell 1996). The implicit assumption is that individual behaviors are driven by their specific objectives and perceptions of the system. Therefore, researchers working with MAS have become increasingly interested in modeling individual representations.

Still, modeling the specific nature of representations is not an easy task as the concept of representation itself is subject to several contrasting theories (Lauriol 1994, Descola 1996, Hutchins 1999). Two main trends can be identified. The first approach, known as cognitivist, states that representations are stabilized knowledge structures that are mentally built using a set of symbols and logical inferences, and that they can be stored in a long-term memory and reused ( Craik 1943, Johnson-Laird 1983). On the other hand, the constructivist approach states that individual representations are temporary constructs elaborated through social interactions and communication and they are highly context-dependent (Piaget 1971). In both cases, knowledge and decision-making are not fully conscious in the mind, either because some of the elements and processes that constitute knowledge and representation are said to be unconscious (Newell 1982) or because the nature of representation is said to be socially constructed and continuously evolving (Röling 1996).

Hence, the modeling issue comes down to a choice between theoretically designed knowledge or empirically elicited knowledge.

### **Modeling from theories**

So far, there is no unified theory in the field of MAS. Coming from artificial intelligence, the belief-desire-intention architecture has long been the most popular theoretical framework (Conte and Castelfranchi 1995). More recently, social scientists have challenged this view and proposed alternative frameworks (Gilbert 1995). Some of these models, such as the Consumat theory, have been tested against experimental data (Jager and Janssen 2003).

### **Companion modeling approach**

Companion modeling is a trend of PMASM dedicated to NRM<sup>1</sup> (Bousquet et al 1999). It involves stakeholders in various phases of the modeling process. Stakeholders provide feedback about the model structure and the simulations produced thanks to iterative interactions with the designers. Several versions of the model might be discussed as its construction evolves (Barreteau and Bousquet 2000). This approach may also use workshops in which models are created in complete interaction with stakeholders. During those working sessions, stakeholders design the model using different model artifacts (computer model, role game) and researchers act as facilitators in this process (Bousquet et al 2002). Two applications of companion modeling are ongoing in northern Thailand, focusing on issues of deforestation (Promburom et al, this volume) or soil erosion (Trébuil et al, this volume).

By building models of stakeholders' representations in a participatory way, this work serves to create a shared representation and to simulate scenarios. This process is especially appropriate for taking into account the social construction of representations and for giving a relevant validation of the model. Now, when looking at previous experiences, a variety of ways have been used for identifying and integrating stakeholders' representations in the models. They may present individual representations either separately from each other or in an aggregated way. Moreover, and depending

---

<sup>1</sup><http://cormas.cirad.fr/en/reseaux/ComMod/index.htm>.

on the goal aimed for, the emphasis is given either to the individuals' representation of their biophysical and social environment or, when individuals' behaviors are highly driven by others' behaviors, to their representation of the others' representations of the environment. Nevertheless, in the community of PMASM users, a common trend is the use of conceptual models (one may use a single model or a set of models) to express the shared representation and therefore the individual representations. But, how do we ensure that the conceptual model holds the individual representations? In some cases, the identification and integration of individual representations are reached through the researcher's understanding of the system dynamics. In other cases, these are ensured through participatory methods such as role-playing games or group discussions. But, the identification and integration of individual representations are often not a formal procedure. Now that PMASM has proven its usefulness in promoting discussions and negotiated scenarios among stakeholders, we felt the need to reinforce the ways to reach the creation of a shared representation.

## Methodological assumptions

We adapted knowledge engineering techniques to our specific working context, which deals with NRM and actors often performing ill-defined tasks. A methodology based on seven elements that constitute its fundamentals was elaborated during a study in the Orb Valley in southern France on wine farmers' perceptions of runoff and erosion processes (Becu et al 2003). The fundamentals of this methodology are summarized below.

### **A constructivist perspective**

We acknowledge the constructivist perspective and believe that the nature of representation is socially constructed through people's interactions with their physical environment and their social relations. We assume also that representations have a psychological existence in people's minds and thus may be elicited. But, we recognize that these representations may evolve due to the elicitation process itself. Therefore, any elicited representation should be used as a basis for discussion rather than decision.

### **The use of elicitation**

Our methodology uses elicitation techniques coming from knowledge engineering as a way to access individual representations. Elicitation consists of asking experts to describe and give information about a system and to model that information. Typically in knowledge engineering, experts are humans possessing special skill or knowledge, derived from training or experience, in some particular field (Gaines 2000). Experts should show abilities in answering questions, explaining results, and identifying issues. Elicitation focuses on the expert's knowledge about a domain and on the way he or she makes decisions. The implicit viewpoint on representation is thus the cognitive approach.

In the field of knowledge engineering, there are different approaches. Within the transfer view that we follow, elicitation and modeling of representations are treated as two successive and independent phases. The eliciting process is composed of a direct acquisition of information, followed by the interpretation of the collected information.

Acquisition may be achieved through semistructured interviews, process monitoring, or ethnographic surveys. These tools are highly complementary as behavioral observation may help in solving communication shortcomings or misunderstandings (Trimble 2000). Although it is severely criticized by knowledge engineers, we consider that individual semistructured interviewing is the most appropriate elicitation technique in the context of our application. When dealing with stakeholders in the context of NRM, interviews and meetings are common and well accepted by local actors. Moreover, we believe that the weaknesses of interviews (interpretation biases and inability to extract tacit knowledge) can be corrected by parallel techniques such as joint field observations, anthropological surveys, or stakeholders' zoning.

Associated with semistructured interviews, the interpretation is often made using the protocol analysis technique, based on the knowledge-level theory (Newell 1982). The principle consists of identifying in the transcript of an interview all the words and semantic expressions related to the elements and concepts that are relevant to the project. The experience of knowledge engineers using protocol analysis has refined and adapted Newell's knowledge-type classification. Knowledge engineers have identified different types of what they call knowledge objects and associated typical words and semantic expressions for each of them (Ehret et al 2000, Gray and Kirschenbaum 2000). That is how, using those classifications, we can extract the knowledge objects of a transcript containing a stakeholder's views on whatever topic and, by combining those pieces of information, we can obtain a conceptual model of the stakeholder's representation. To integrate representations in a running MAS model, we also adapted the knowledge objects classification to the unified modeling language (UML) formalism often used in MAS (Le Page and Bommel, this volume) and that greatly facilitates the implementation phase (Grady et al 1998, Graham 2001).

### **Taking situated cognition into account**

Situated cognition theory considers that representations are context-dependent (Gigerenzer and Todd 1999, Menzies 1996). Thus, we try to place the interviewees in a context that makes sense for the topic of the representation that is examined. In their transect method, Ross and Abel (2000) make it possible to extract information concerning spatially distributed processes by interviewing stakeholders during a walk across the case study area. Similarly, in our methodology, (1) interviews should be done in the field, at a location relevant to the interviewee's actions, and (2) the interviewer's first question should be related to the interviewee's main actions at this location.

### **Use of multi-agent systems**

Our main reason for choosing MAS is that it is especially appropriate for taking into account the heterogeneous social representations of a system and has been proven to be highly useful in simulating agents with different viewpoints and behavior (Ferber 1995, Etienne et al 2003). Moreover, it can be used to explore stakeholders' representations in a dynamic way, which is useful for our methodology in two ways. On the one hand, it allows us to check the model consistency according to the stakeholders' authentication of its different components. On the other hand, simulations developed with MAS are very efficient communication media as the model presented on a computer screen displays the environment in a simple and synthetic way. One of the best

pieces of evidence of this is the selfCormas application, for which Senegalese farmers were able to discuss MAS results displayed on the screen of a laptop (Bousquet et al 2002, D'Aquino et al 2003).

### Northern Thailand application

The northern Thailand application aims at modeling resource management for a small catchment, with the integration of stakeholders' representations using the above methodology. Research work was divided into three phases: data collection, data analysis, and validation. We will first describe the fieldwork context and then the three phases. As this research is still ongoing, this paper will focus on the elicitation process. Perspectives about the modeling process will be presented in the next section.

#### The context in village highlands and lowlands

Within the framework of a broader collaboration with the Land Development Department of Thailand, we have selected the Pang Da catchment, which occupies 15 km<sup>2</sup> and is located about 30 km northwest of Chiang Mai City. As we were also interested in lowland irrigated water management systems, we extended the study area to the portion of the Samoeng River located downstream from its confluence with the Pang Da River. Thus, this area is hydrologically dependent on the Pang Da catchment. A rapid rural appraisal was carried out and two main case studies were selected for the elicitation and modeling of farmers' representations. Each of these case studies, an upstream and a downstream village, has specific social, agricultural, and economic contexts (Fig. 1).

The upstream case study (1,250 m) is a Hmong ethnic group village of 103 households and a population of approximately 700 individuals, called Buak Jan. Agriculture is characterized by vegetable and flower production. There are two water sources for irrigation: small streams and a spring in the middle of the village. Streams are often private property and water sharing occurs principally among relatives, but the spring is an open-access water source and no collective management rules are defined at this level. The local issue of this case study is the lack of water for irrigation during the dry and warm season (March to May). Indeed, by February, streams are usually dry and farmers can count only on the spring from which they have to pump water to irrigate. In addition to consuming electricity and money, this spring dries up during average hydrological years at the beginning of May, resulting in an

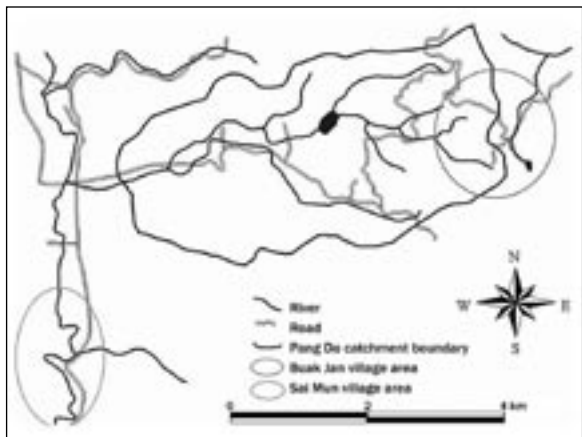

Fig. 1. Map of the study area.

incapacity to irrigate for about 2 weeks. For flower production, which is dominant at this time of the year, this drought results in a decrease in flower plant production and sometimes in the death of a part of the flower plants. During dry years, drought can last for 1 month or more. Free water access to the spring results in a heterogeneous pattern of individual satisfaction, leading to indifference toward the global water scarcity problem for farmers who always have water and to irritation for those who are less successful than others in getting water first.

The downstream case study (540 m) is a northern Thai village of 102 households and a population of approximately 500 individuals, called Sai Mun. Agriculture, which is the activity of most villagers, relies mainly on paddy field cultivation. Those paddy fields are irrigated areas belonging to three irrigated schemes with similar individual and collective water management. Farmers grow rice for home consumption during the rainy season and cash crops during the dry season (November to May). Contrary to what we thought at first, the cropping pattern is not driven by water management but highly depends on soil fertility. Most farmers had continuously grown garlic for about 20 years during the cold season as a high-value cash crop. This factor, together with others, has resulted in a decrease in soil fertility (decrease in soil nutrients, organic matter, and pH; soil structure disintegration), which has affected garlic and other cash crop yields for about three years. Farmers react to this problem in heterogeneous ways: for example, some try new cropping patterns, other than garlic, that are supposed to improve soil fertility, and others apparently ignore the problem and keep on cropping as they always did.

As farmers act on their system and react to local issues in different ways, we assume that these heterogeneous behaviors depend on each farmer’s representations of the biophysical and social environment. Describing and modeling those representations should then lead to a better understanding of farmers’ actions and therefore of the system dynamics. To do this, we conducted an elicitation process in both case studies that was divided into three phases. Data produced at each phase were used as inputs for the next phase (Fig. 2).

**Ethnographic and project surveys**

Two different interviewing approaches were used in two separate villages: individual semistructured interviews and individual discussions (some would call them open interviews) combined with observations.

In Buak Jan, 12 individual semi-structured interviews were conducted within the framework of a formal research project about water manage-

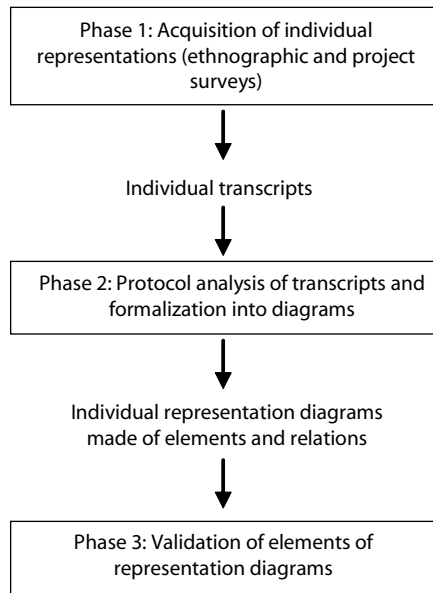

**Fig. 2. Phases of the methodology and information transferred between each step.**

ment established with the village headman. Each interview was done in the farmer's field after having met him previously two or three times to ensure a good relationship between the interviewee and interviewer. We tried to diminish Thai-English interpretation biases by training the translator on the semistructured interviewing techniques and by conducting the interviews as much as possible in Thai and recording them. The recorded interviews were translated verbatim afterward, resulting in an English transcript. However, this necessary translation phase definitely resulted in obvious losses or misinterpretations of the farmers' words and even more, considering that Thai is not the native language of the Hmong people. Topics tackled in the interviews were defined in collaboration with the headman's village but more important than the topics themselves for the focus of this paper is the type of questions asked of the farmers. As our interest was in collecting the interviewee's representation of his environment, topics were introduced through "How does this operate?" type questions when talking about an environmental state, through "Why is this so?" type questions when talking about an environmental dynamics, and through "What do you do about X and why?" type questions when talking about an action. Prompting questions were then used within each topic, either to invite the interviewee to develop his argument or to talk about a predefined subtopic. After interviewing, we reread the transcripts and prepared additional questions that we asked of the same farmers approximately 1 month after the first interview.

The Sai Mun study was conducted with a different fieldwork approach, which has more to do with ethnographic work than an interviewing approach. As no formal framework was defined for our presence in the village, the research team developed a relationship with the villagers through a continuous presence among them for 7 months, joining them in agricultural activities and discussing various topics about their lives. As contact with farmers became closer, discussions were refined and more explicit questions were asked. The types of questions asked were of the same nature as in Buak Jan ("Why is this so?", "What is happening here?"). When our understanding of the system issues became more accurate, we used the soil fertility issue as a way to structure a discussion guideline about farmers' representations of their environment. Fourteen individual discussions following this guideline were conducted in the field with the help of a translator. As we didn't want to use the tape-recorder because of the informal relation of the research with the village, we developed with the translator a note-taking technique to ensure a minimum loss of information during the process: (1) during the interview, rapid note-taking; (2) just at the end of the interview, quickly completing the missing parts of the notes; (3) in the following hours after the interview, chronological rereading of notes to complete missing parts and, as far as we could recall, rewriting the conversation in the way that the interviewee expressed it.

As ethnographic or project surveys may be considered as a method on their own for identifying farmers' representations, it was important to keep track of the representations identified at this stage before starting the next research phase. By doing so, we were able to compare the results of ethnographic and project surveys with those of transcript analysis (which is another method for identifying representations) and thus discuss the representations' elicitation aspects of these two approaches. The results were presented in the format of classifications of farmers' representations. In this paper, we present only the classification of Sai Mun farmers built from an ethno-

**Table 1. Classification of farmers in Sai Mun: classification 1 in columns and classification 2 in rows.**

Classification 1	Work alone		Work with agricultural partners	Not classified
	Open-minded	Not open-minded		
Classification 2				
Wide representations (initiator)	F11, F5		F12, F9, F3	F1
Narrow representations (follower)				
Focus on profit maximization	F4, F10	F8, F13		F14
Not self-confident	F2	F7		
In between				F6

graphic-type fieldwork approach. The comparison with the transcript analysis results will be presented later in this paper.

For Sai Mun, two classifications of farmers’ representations were produced separately by different members of the research team (Table 1). In classification 1, farmers are classified according to their behavior toward agricultural partners: work alone or in contract with companies or institutions. Within the first group, farmers are divided according to their open-mindedness (open-minded or not). In classification 2, farmers are classified according to the “wideness” of their representations. The “wide representations” category corresponds to farmers taking many elements into account when making decisions about cropping or about resource management, whereas farmers within the “narrow representations” category are analyzing the system in a simple way (taking few elements into account for decision-making). We also found a parallel with an initiator/follower classification assuming that initiators need many elements when making decisions, whereas followers don’t because they base their decisions on what others have experienced already. For the second group, we distinguish between farmers who are followers because (1) they focus only on profit maximization and they don’t want to spend time thinking about biophysical dynamics, and (2) they are not self-confident for various reasons, mainly social reasons.

**Transcript analysis**

This phase aimed at extracting through a protocol analysis of the individual transcripts the elements and relations that would form the individual representations of the farmers. As a matter of fact, even if knowledge objects used in protocol analysis can all be classified in terms of elements and relations, their definition can be more precise than two categories only. However, we chose this classification for simplification as we intended to use the resulting conceptual model for further discussions with the farmers. The classification used for the protocol analysis is shown in the last column of Table 2.

The protocol analysis started with the preparatory phase of the transcripts. When multiple interviews had been done with the same farmer (as in the case of Sai Mun), transcripts were merged. The transcripts were then reread farmer per farmer to split each transcript into various themes. Themes were chosen both according to the themes

**Table 2. Correspondences among knowledge objects, UML formalism, semantic expressions, and the classification used for protocol analysis in the northern Thailand case study.**

Knowledge object	UML <sup>a</sup> formalism	Semantic expression	Classification used
Concept (object, person, etc.)	Class	Usually equivalent to nouns	Element
Instance	Instance	Ex.: "my car" is an instance of "car"	Element
Process (task, activity)	Operations	Ex.: "build a house," "design the engine"	Relation
Attribute and value	Class attribute and instance of attribute's value	Attribute: ex.: "cost," "age" Value: ex.: "120 kg," "heavy"	Attribute
Rule	Methods	Ex.: "If..., then...," "Do... until..."	Relation
Relationship	Association, aggregation, or inheritance	Usually equivalent to passive verbs; ex.: "...is a...," "...is part of..."	Relation

<sup>a</sup>UML = unified modeling language.

defined before the interviews and discussions and the actual themes discussed by the farmers (e.g., no specific theme for cropping was predefined before the interviews and discussions but this theme appeared explicitly during the discussions). Themes were identical for each farmer in each case study; however, when the information in a transcript was quite limited, we didn't feel the need to do the thematic classification. It appeared to us that the thematic classification was rather more a way to organize the protocol analysis when information was very rich than an analysis by itself. Moreover, after their identification with protocol analysis, elements and relations extracted from each farmer were combined in an individual diagram by whatever themes they were belonging to at first. The exception to this aggregation of the different themes is the case of Buak Jan, whose diagrams appeared to be very "wide" (numerous elements and relations), and which we split into four individual thematic diagrams to make them easier to understand. Examples of the resulting individual diagrams are given in Figures 3 and 4.

As shown in these figures, the diagrams resulting from the elicitation process are not easily readable at first. However, distinctions can be made. Figure 3 shows a soil-oriented representation of a Sai Mun farmer, whereas other farmers' diagrams from the same village show a market- and selling-oriented representation. These orientations are shown by the type of elements found in the diagrams as well as by the great number of converging relations going to the element "soil" in Figure 3, for example. Figure 4 is an example of the higher quantity of information elicited in Buak Jan, as we already stated above. Thus, the total number of elements for Buak Jan farmer 4 is 41, whereas there is a maximum of 19 elements per individual representation in Sai Mun village.

Although the diagrams' first reading could give information about their orientation, we conducted a qualitative analysis of them to extract more accurate results and establish a farmers' classification. Within the literature on qualitative data analysis, the concept of grounded theory is used when talking about theories formulated from

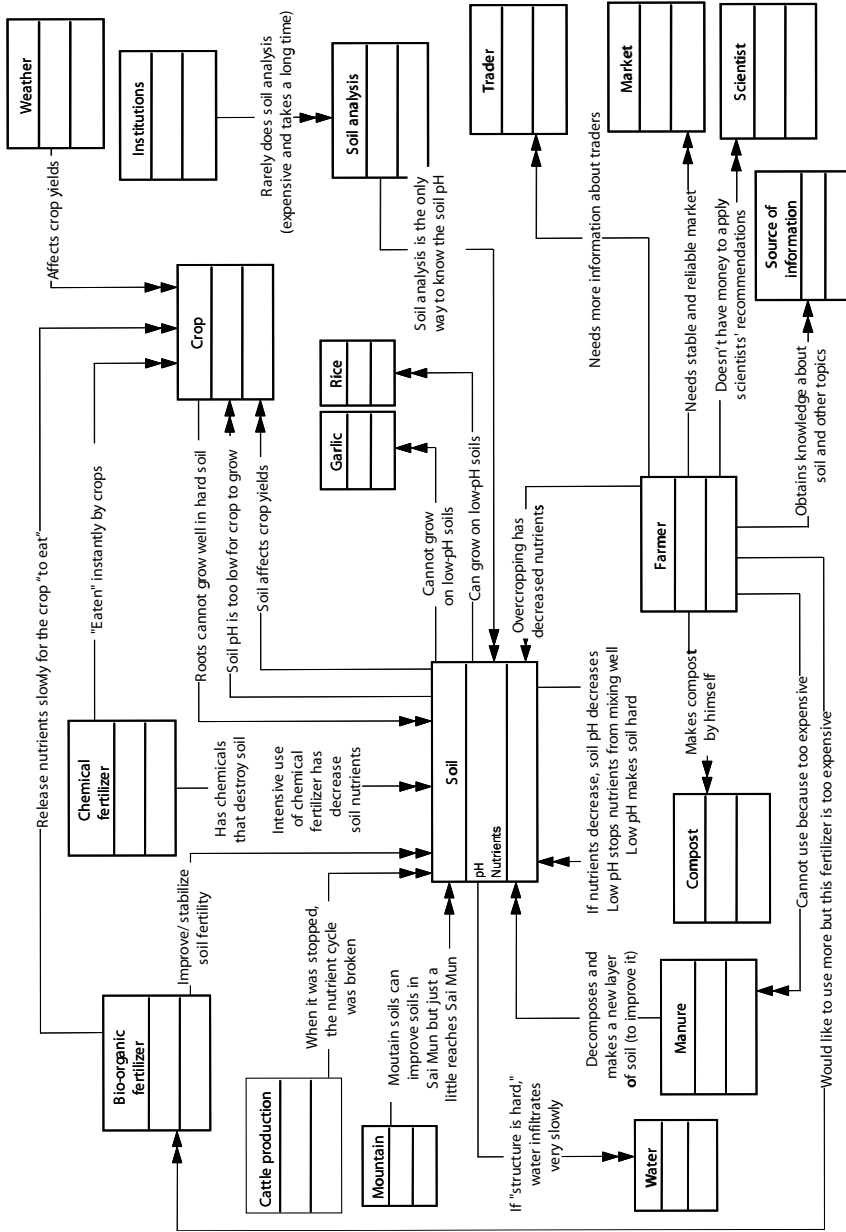
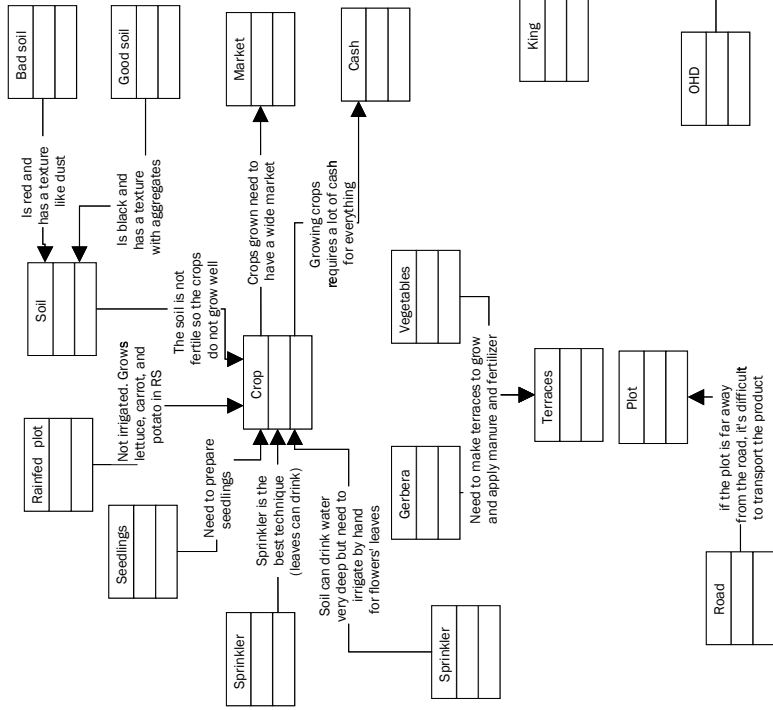

Fig. 3. Farmer 11 representation: example of soil-oriented representation in Sai Mun village.

Farmer 4 representation of cropping



Farmer 4 representation of soil

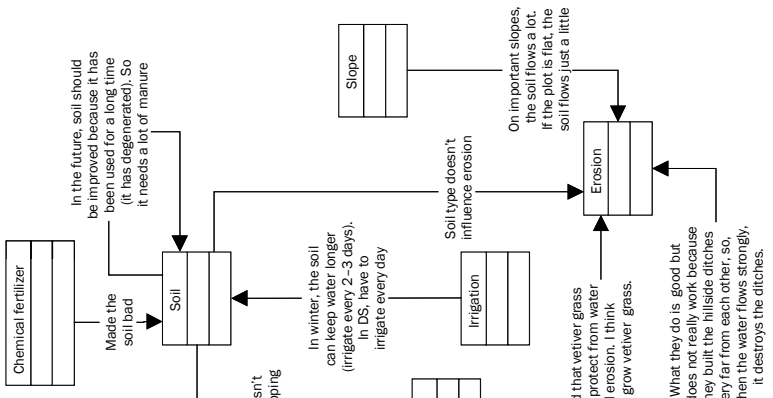

Fig. 4. Parts of farmer 4 representation: representation of cropping and of soil in Buak Jan village. RS = rainy season, DS = dry season, OHD = Office of Highland Development.

empirical observations. Practitioners develop theories through induction based on observation of a phenomenon (Glaser and Strauss 1967). This bottom-up approach uses some techniques that are especially relevant for our purpose. The formulation of a new theory begins by coding the data and formulating relationships among the coded objects, just as we have done with the elements of the farmers’ representations.

Then we define two criteria—groundedness and density—that refer to the code frequency and to the relation frequency, respectively (Strauss and Corbin 1990). For the analysis of the individual representation diagrams, we adapt the two previous criteria to our data set. We defined two main indicators: the number of elements and the number of relations within an individual representation. For Sai Mun village, we have also calculated the number of relations with the element “crop” and the number of relations with the element “soil.” Crop and soil are chosen because they are among the main elements used by Sai Mun farmers. Those indicators were then used to establish classifications of Sai Mun and Buak Jan farmers. In Table 3, for Sai Mun farmers, the numbers of elements and relations have been expressed in terms of relative quantity ranges. The same kind of table was made for Buak Jan farmers.

A comparison with the ethnographic approach classification shows that the extreme groups correspond in both classifications (group 1 corresponds to the “wide” representations group; groups 5 and 6 correspond to the “narrow” representations and not self-confident group, except F3). However, the “narrow” representations focusing on the profit maximization subgroup are distributed among very different groups of the postanalysis classification. A main reason for this inconsistency is the preanalysis classification inclination toward cropping and soil issues rather than toward economic issues. That kind of comparison is interesting as it reveals weaknesses and strengths of each type of classification. Indeed, the general convergence of the two classifications for Sai Mun village confirms in some way the relevance of the fieldwork approach adopted in Sai Mun village, as our preanalysis understanding of the system seemed quite accurate. However, incoherence such as with the profit-oriented subgroup demonstrates that a preanalysis classification is very dependent on our personal orientation toward the topic studied. Moreover, when comparing the preanalysis and postanalysis classifications for Buak Jan, many more mismatches were found and we are tempted

**Table 3. Classification of Sai Mun farmers according to number of elements and range of relations.**

Group	Farmer	No. of elements <sup>a</sup>	No. of relations		
			Total	With crop	With soil
1	1,9,12	+	++	++	++
2	13,14	+	++	++	+
3	11	++	++	+	++
4	5,6	0	0	+	+
5	2,8	+	-	+	-
6	3,4,7,10	-	--	-	-

<sup>a</sup>+++ = very numerous, ++ = numerous, + = medium, - = few, -- = very few.

to attribute this to the Buak Jan fieldwork approach, which resulted in a less accurate understanding of the system than in Sai Mun.

If the use of groundedness and density criteria resulted in a first interesting classification, it was unable to convey the orientations of the representations, such as soil- or market-oriented. Therefore, we worked on a second classification based on the type of elements embedded in each representation. This will be discussed later on in this paper.

### **Uncovering elements of the individual's representation through “playable stories”**

*Establishing a methodology.* When it came to the phase of validation of our findings in terms of the actual individual representations of farmers in both case studies, it appeared clearly that validating both elements and interactions of our diagrams was too much to do all at once. Indeed, the total amount of different elements found in Sai Mun, for example, was more than 90 for all farmers. When we started to count the number of different relations, we quickly arrived at more than 100 types of interactions, after which we stopped counting. For the Buak Jan case study, the numbers were even larger. Validating such great diversity, element by element and relation by relation, was unrealistic; thus, we decided to focus on validating the important elements of the individual representations. Therefore, we identified around 60 main elements for each case study from the analysis of the individual representation diagrams and used them during individual sessions we conducted with each farmer of the sample. Those sessions are halfway between gaming sessions and story telling; we thus called them “playable stories.”

Playable stories aimed to lead farmers to rebuild their world by selecting and organizing the elements of their world that were dominant in their representational system. The elements selected by each farmer during those sessions were then compared with the ones in their representation diagram as a means of validation. Each of the 60 elements mentioned above was therefore transcribed onto a card on which the name of the element was written in Thai and English (e.g., one card for weir, one card for trader, one card for rice, etc.). The 60 resulting cards were then placed on a panel in such a way that farmers could have an overview of the different elements at a glance (see Fig. 5).



**Fig. 5. Cards for each element are placed on a panel for farmers to see them all at a glance.**

To invite farmers to choose cards, as well as with regard to the situated cognition assumption, a story giving broad elements of the surrounding environment was recounted during the session so that farmers could locate themselves in a real-world context. The story told was the same for each farmer of a village and included different periods in which one topic at a time was emphasized. For example, for the Sai Mun case study, the first period focused on water management and the second and third focused on soil and market, respectively. Within this virtual world, farmers were invited to act, make decisions, choose cards that they thought were important for their way of life, and organize them if they wanted to.

To make those sessions a bit more entertaining, we added features such as virtual bank notes, which were used to pay and earn money, and meetings within the story with different stakeholders of the system with which the farmer was invited to converse (such as a soil scientist, a canal manager, a banker, a trader). Our story became a kind of gaming session and it was presented to farmers as one.

As a way to combine different approaches for identifying the important elements of the farmers' representations with this methodology, we organized the sessions in three separate and consecutive phases. In phase 1, we presented the board on which the cards were placed and asked the player to pick the one that he thought was important for his occupation. During phase 2, we recounted our story, step by step and year by year (one year is divided into six steps), and asked the farmer to "act" within this story as explained above. During this phase, the panel with the cards was hidden from the farmer and, while he was explaining what he was doing within the story, one of the interviewers was choosing the cards corresponding to the elements mentioned. When an element mentioned wasn't already available in the panel, a new card was added. All cards chosen, in all phases, were placed on a central board visible to all. During phase 3, we presented the panel to the farmer a second time with all the cards that he didn't mention or choose yet and we asked him to pick some new elements if he wanted to. Then, we discussed the different cards or groups of cards that were placed on the central board as a way to enrich the discussion. We also used cords to represent the interactions mentioned by the farmers (see Fig. 6).



**Fig. 6. Cards of the board are linked with cords corresponding to interactions between elements.**

*Assessing the interest of “playable stories” for revealing elements.* The research on and use of those playable stories to validate the elements of farmers’ representations is still ongoing and only preliminary outputs can be mentioned. One primary output is that those sessions were able to reveal tendencies of the farmers’ behavior in the game; for example, some farmers focused more on the market and earning aspects whereas others were oriented toward soil management. Identification of those main farmer representation orientations first came from our general impression at the end of each session; for example, some farmers spoke much more about elements related to the soil, whereas others were always arguing about prices, incomes, and markets. But, much more important than these subjective impressions, we were able to identify and describe those orientations by analyzing the set of cards that were chosen during the session. Indeed, as we recorded all the cards picked during the session, we could quantify and analyze objectively what happened during the sessions and this analysis confirmed the ability of the playable story to reveal the orientations of farmers’ representations. In more details, with some cards being used or mentioned by the players more than other cards, we could weight the relative importance of the different cards. To do so, during the game we recorded players’ reactions about the cards by arguing, giving comments, or asking information about a card. We then summed the number of times a farmer used, mentioned, or reacted to a card and assimilated the sum total to the weight of the element. We are currently combining these quantitative results with qualitative data extracted from the game (the verbatim transcriptions of farmers’ reactions about cards) and preliminary results show that they contribute well to the definition of farmers’ orientations toward specific interests.

## Discussion

This paper focuses on the test of various methods for identifying and formalizing farmers’ representations. We therefore presented the construction, application, and some preliminary results of those methods. Although this research is still ongoing, it is possible at this stage to assess the methodology from our experience. Moreover, an interesting specificity of this methodology is that it was applied at an individual level. This enabled us to demonstrate the heterogeneity of farmers’ points of view, which we discuss in the second part of this section.

### **Methodology assessment**

During the course of this research, we have tried diverse approaches for collecting information. Our aim was to find methodological elements that would tend to more accurately reflect the stakeholders’ representations collected. An important source of bias when collecting this kind of information is the relationship between the interviewer and the interviewee (Portmann and Easterbrook 1992). Factors such as mistrust between the two persons may lead the interviewee to distort his answers. Knowledge engineers practicing elicitation techniques also demonstrate that meeting each interviewee several times is useful for creating a trustful relationship (Lépy 1997). The ethnographic and project survey approach used in Sai Mun and Buak Jan villages, respectively, resulted in a different nature of the relationship between the interviewer and interviewees. Although it is difficult to assess this relationship objec-

tively, we believe that the ethnographic approach enabled a more trustful relationship that resulted in more accurate responses from the interviewees. In contrast, the project survey approach was much less time-consuming. Moreover, as audio-recording was used with this approach, it resulted in more information per transcript than with the ethnographic approach.

The representation diagrams completed in phase 2 (Figs. 3, 4) show interesting results as they show the elements of the system and the relations among those elements, but they also carry in their structure the orientations of the person's representation and his strategies (that may intervene in the decision-making process). Thus, when looking at a single individual diagram, one can follow the train of thought that demonstrates some logic of thinking or strategies. Still, those diagrams have limitations when one tries to analyze them collectively. We were able to use the different types of elements and relations to define classes of representations among the individual diagrams, but we were lacking methods to compare them according to elements such as train of thought or strategies. This difficulty may also partly be explained by the fact that each strategy or logic of thinking also contains series of elements and relations. This also demonstrates that tendencies and similarities can be found among several individuals in terms of elements referring to a specific topic, but that these individuals organize those similar elements in different ways.

Preliminary results of playable stories show some elements of interest regarding the nature of the representation extracted with this method. When compared with the elements of the representation diagrams, the type of elements extracted with playable stories are much more oriented toward actions and decision-making. Elements such as forest, mountain, or underground are never mentioned by the farmers during the playable stories. Once again, situated cognition theory contains elements of discussion that can explain these differences. Indeed, the context in which the interviewees are placed during the interviewing phase and the playable story is different. During the interviews, farmers were asked to discuss their environment in a general way, explaining processes of various elements and reasons for their thoughts and actions. In contrast, during the playable stories, interviewees were asked to act in their environment and eventually to comment on it as well as the reasons for acting in such a way. Therefore, farmers expressed their representation of the environment oriented toward action within the playable stories, whereas they had revealed their representation of the environment in a generic way during the interviews. Thus, current results tend to show that farmers use some parts of their representation of the environment when making decisions and performing tasks. Reasons for such behavior may be arising from simplifications, which are often made during a decision-making process, made to restrict a choice to its core (Gigerenzer and Todd 1999).

### **Importance of heterogeneity of representations and modeling perspectives**

All the way through the identification process of our methodology, we found specific perspectives that farmers have for different aspects of their system. Elements and relations of the diagrams reveal that some farmers are more oriented toward soil, some toward market and selling aspects, and some toward partnership with private companies or institutions. Orientations revealed by playable stories complement the previous and help refine the profile of each farmer. These results are very demonstrative

of the heterogeneity of farmers' perceptions of their social and natural environment and how they react to specific issues. In the case of Sai Mun, for example, farmers whose representation is oriented to soil aspects perceive the decrease in soil fertility as the result of the intensive use of chemical fertilizer associated with garlic production. They developed a thinking process about the relations among chemical fertilizer (as well as other inputs), soil, and plant. This process is based on their own experience, on comparisons with other farmers' practices, and on technical information they acquired from the radio or from technicians from local institutions. The conceptions that resulted from their thinking process as well as the source of information used are reflected in the diagrams. For example, Figure 3 shows the conception that the farmer has of the benefit of manure for soil fertility and how he perceives the pH as being dependent on soil nutrients. These conceptions result in specific decisions. That is why the farmer of Figure 3 will not grow garlic on a plot in which he thinks the soil is acidic but will grow soybean instead, or will use manure. Now, in the same village, the representation diagrams oriented toward profit aspects reveal a completely different view and reaction to the soil fertility issue. Those farmers explicitly refer to the soil as a resource used for production that can be managed. Investment is then the means to improve soil fertility. Here, the use of chemical fertilizer is not reappraised and should be completed by additional inputs such as bioorganic fertilizer. Similarly, those farmers will stop growing garlic if they consider that it is not profitable given the additional inputs required.

Throughout this example about farmers' conceptions and reactions to soil fertility, we showed that the representation diagrams can explain farmers' way of thinking and how different conceptions of a system result in different decision-making. The next step of this research now consists of integrating those different representations into the modeling. The coauthors of this paper foresee two main possibilities for integrating representations into the modeling. On the one hand, the model is a direct transcription of the stakeholder's representation and all objects of the model correspond to an element elicited within at least one farmer's transcript. On the other hand, agents introduced in the model use the representation and those agents interact with other objects that are coming from scientific knowledge and not from elicited elements. Figure 7 gives a schematic representation of these two forms of stakeholders' representation models.

Our aim is now to apply our reflections on the integration of individual representations into the modeling to the northern Thailand data set and to submit the resulting models to the stakeholders. Even if the representations elicited were only the ones of the farmers of the catchment, after the playable story phase, most farmers spontaneously asked us to organize meetings with this type of playable stories grouping together diverse types of stakeholders (government institutions, the Land Development Department, the Royal Project Foundation, etc.). Our perspective is thus to organize feedback working sessions with all stakeholders' groups, present our models, and use them as a way to discuss the diverse representations and ways of thinking present in the catchment.

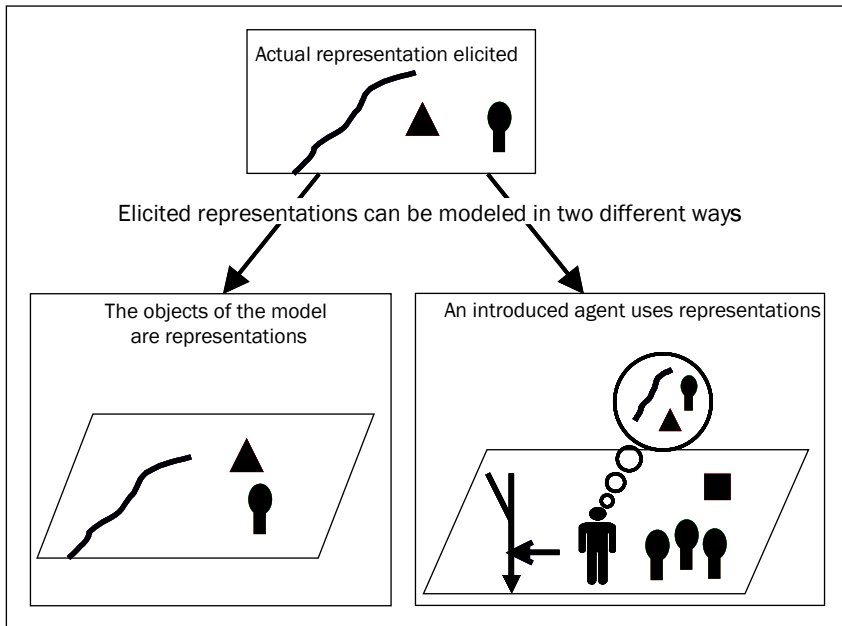

**Fig. 7. Two types of stakeholders' representation models.**

## References

- Alford D. 1992. Streamflow and sediment transport from mountain watersheds of the Chao Phraya Basin, northern Thailand: a reconnaissance study. *Mountain Res. Dev.* 12(3):237-268.
- Barreteau O, Bousquet F. 2000. SHADOC: a multi-agent model to tackle viability of irrigated systems. *Ann. Operations Res.* 94:139-162.
- Barreteau O. 2003. The joint use of role-playing games and models regarding negotiation processes: characterization of associations. *J. Artif. Societies Social Simul.* 6(2).
- Becu N, Bousquet F, Barreteau O, Perez P, Walker A. 2003. A methodology for eliciting and modeling stakeholders' representations with agent-based modeling. In: Hales D, Edmonds B, Norling E, Rouchier J, editors. *Multi-agent-based simulation iii. 4th international workshop, MABS 2003, Melbourne, Australia, July 2003, revised papers.* Lecture Notes Artif. Intell. 2927:131-148.
- Bousquet F, Barreteau O, Le Page C, Mullan C, Weber J. 1999. An environmental modelling approach: the use of multi-agent simulations. In: Blasco F, Weill A, editors. *Advances in environmental and ecological modelling.* Amsterdam (Netherlands): Elsevier. 219 p.
- Bousquet F, Barreteau O, D'Aquino P, Etienne M, Boissau S, Aubert S, Le Page C, Babin D, Castella J-C. 2002. Multi-agent systems and role games: collective learning processes for ecosystem management. In: Janssen MA, editor. *Complexity and ecosystem management: the theory and practice of multi-agent approaches.* Cheltenham (UK)/Northampton (USA): Edward Elgar Publishers. p 248-285.
- Brown V, Smith DI, Wiseman R, Handmer J. 1995. *Risks and opportunities: managing environmental conflict and change.* London (UK): Earthscan Publications Ltd.

- Carpenter S, Brock W, Hanson P. 1999. Ecological and social dynamics in simple models of ecosystem management. *Conserv. Ecol.* 3(2).
- Conte R, Castelfranchi C. 1995. Norms as mental objects, from normative beliefs to normative goals. In: Castelfranchi C, Muller JP, editors. *From reaction to cognition*. Berlin (Germany): Springer Verlag. p 186-199.
- Craik K. 1943. *The nature of explanation*. Cambridge (UK): Cambridge University Press.
- Crowfoot JE, Wondollock JM. 1990. *Environmental disputes: community involvement in conflict resolution*. Washington, D.C. (USA): Island Press.
- D' Aquino P, Le Page C, Bousquet F, Bah A. 2003. Using self-designed role-playing games and a multi-agent system to empower a local decision-making process for land use management: the SelfCormas experiment in Senegal. *J. Artif. Societies Social Simul.* 6(3).
- Descola P. 1996. Constructing natures: symbolic ecology and social practice. In: Descola P, Palsson G, editors. *Nature and society: anthropological perspectives*. London (UK): Routledge. p 82-102.
- Ehret BD, Gray WD, Kirschenbaum SS. 2000. Contending with complexity: developing and using a scaled world in applied cognitive research. *Human Factors* 42(1):8-23.
- Enters T. 1995. The economics of land degradation and resource conservation in northern Thailand: challenging the assumptions. In: Rigg J, editor. *Counting the costs: economic growth and environmental change in Thailand*. Singapore: Institute of South East Asian Studies.
- Epstein JM, Axtell R. 1996. *Growing artificial societies: social science from the bottom up*. Brookings Press and MIT Press.
- Etienne M, Le Page C, Cohen M. 2003. A step-by-step approach to building land management scenarios based on multiple viewpoints on multi-agent system simulations. *J. Artif. Societies Social Simul.* 6(2).
- Ferber J. 1995. *Les systèmes multi-agents: vers une intelligence collective*. Paris (France): InterEditions.
- Gaines BR, Shaw MLG. 1993. Eliciting knowledge and transferring it effectively to a knowledge-based system. *IEEE Trans. Knowl. Data Eng.* 5(1):4-14.
- Gaines BR. 2000. *Knowledge science and technology: operationalizing the enlightenment*. Lecture notes of PKAW2000, Pacific Rim Knowledge Acquisition Workshop, Sydney, Australia, December 2000.
- Gigerenzer G, Todd PT. 1999. *Simple heuristics that make us smart*. Evolution and Cognition Series, ABC Research Group, Oxford University Press. 384 p.
- Gilbert N. 1995. *Simulation: an emergent perspective*. Conference on New Technologies in the Social Sciences, Bournemouth, UK.
- Glaser BG, Strauss AL. 1967. *The discovery of grounded theory: strategies for qualitative research*. Chicago, Ill. (USA): Aldine.
- Grady B, James R, Ivar J. 1998. *The unified modeling language user guide*. Addison-Wesley.
- Graham I. 2001. *Object-oriented methods: principles and practice*. Object Technology Series, Addison-Wesley, 3rd edition.
- Gray WD, Kirschenbaum SS. 2000. Analyzing a novel expertise: an unmarked road. In: Schraagen JMC, Chipman SF, Shalin VL, editors. *Cognitive task analysis*. Mahwah, N.J. (USA): Erlbaum. p 275-290.
- Hutchins E. 1999. Mental models as an instrument for bounded rationality. *Proceedings of the Dahlem workshop on bounded rationality: the adaptive toolbox*, 18 May 1999.
- Jager W, Janssen M. 2003. The need for and development of behaviorally realistic agents. *Lecture Notes Artif. Intell.* 2581:36-49.
- Johnson-Laird PN. 1983. *Mental models: towards a cognitive science of language, inference,*

- and consciousness. Cambridge (UK): Cambridge University Press; Cambridge, Mass. (USA): Harvard University Press.
- Kanwanich S. 1997. Agricultural war: the case of the drying rivers. *Bangkok Post*, 20 July 1997.
- Lansing JS. 1991. *Priests and programmers*. Princeton, N.J (USA): Princeton University Press.
- Lauriol J. 1994. Approches cognitives de la décision et représentation sociale. *Rev. Int. Systém.* 8(2):139-166.
- Lépy N. 1997. Expertise et acquisition des connaissances en intelligence artificielle. In: SPI'97, Rennes, France.
- Menzies TJ. 1996. Assessing responses to situated cognition. *Proceedings of the KAW '96: Banff Knowledge Acquisition Workshop*, 21 September 1996.
- Menzies TJ. 2002. Knowledge elicitation: the state of the art. In: Chang SK, editor. *Handbook of software engineering and knowledge engineering*. Volume II. Singapore: World-Scientific.
- Missingham B. 2000. Participatory development in Thailand: a review of some relevant literature. *Integrated Catchment Assessment and Management Centre*, Australian National University, Canberra, Australia.
- Newell A. 1982. The knowledge level. *Artif. Intell.* 18:87-127.
- Piaget J. 1971. *Science of education and the psychology of the child*. New York (USA): Viking Press. (In French: *Psychologie et pédagogie*, 1969.)
- Portmann M-M, Easterbrook SM. 1992. PMI: knowledge elicitation and De Bono's thinking tools. *Proceedings of EKAW-92, Sixth European Workshop on Knowledge Acquisition for Knowledge Based Systems*, Heidelberg, Germany, May 1992.
- Röling N. 1996. Towards an interactive agricultural science. *Eur. J. Agric. Educ. Ext.* 2:35-48.
- Ross E, Abel N. 2000. Eliciting mental models of landscape processes: the transect method. In: Moore GT, Hunt J, Trevillion L, editors. *Environment-behaviour research on the Pacific Rim*. Sydney (Australia): Faculty of Architecture, University of Sydney. p 295-310.
- Rouchier J, Bousquet F. 1998. Non-merchant economy and multi-agent systems, an analysis of structuring exchanges. *Lecture Notes Artif. Intell.* 1534:111-123.
- Schmidt-Vogt D. 1998. Defining degradation: the impacts of swidden on forests in northern Thailand. *Mountain Res. Dev.* 18(12):135-149.
- Strauss AL, Corbin J. 1990. *Basics of qualitative research: grounded theory procedures and techniques*. Newbury Park, Calif. (USA): Sage.
- Trimble JA. 2000. Structuring knowledge acquisition in software development projects. *South African Comp. J.* 26:172-180.
- Vorapien P. 1994. Villagers say fires set deliberately. *Bangkok Post*, 13 March 1994.
- Walker A. 2003. Agricultural transformation and the politics of hydrology in northern Thailand. *Dev. Change* 34(5):941-964.
- Waranoot T, Bengtsson BE. 1993. A conflict over natural resources between highland and lowland populations in Thailand. Paper read at *Tropical Rainforest Research—Current Issues*, April 1993, at Bander Seri Begawan.

## Notes

*Authors' address:* CIRAD-Ca, 73 rue J.F. Breton, 34398 Montpellier Cedex 5, France, email: nicolas\_becu@yahoo.com.